

Course Code: B20HS1101							
SAGI RAMA KRISHNAM RAJU ENGINEERING COLLEGE (A)				R 20			
I B. Tech I Semester –MODEL PAPER							
ENGLISH							
Common to AIDS,CE,CSE,ECE,EEE,IT&ME							
Time : 3Hrs.			Max. Marks: 70				
Answer any one Question from EACH UNIT.							
All questions carry equal marks.							
				M	CO	KL	
UNIT-I							
1	a.	Compose an essay on “A Drawer full of happiness”.			7	2	K3
	b.	Identify & Write suitable verb forms for the following. i) He _____ (work) in the college when his brother studied his engineering. ii) He _____ (finish) his task before his friend visited him. iii) As soon as he _____ (get) the telegram, at once he started. iv) It is high time she _____ (do) her project.. v) The book _____ (comprise) five chapters. vi) The photo of my grandfather _____ (hang) on the wall. vii) Neither team _____ (score) any goal.			7	5	K3
OR							
2	a.	Compose an essay on any ONE of the following. i) Pros and cons of Social Networking Sites    ii) The essence of education			7	2	K3
	b.	Read the following passage and answer the questions that follow:  Liquids are practically incompressible. Unlike gases but like solids, a liquid does not change much in volume when the pressure on it is changed, even when the pressures of thousands of atmospheres are involved. The kinetic theory accounts for this saying that the amount of free space between the molecules of a liquid has been reduced almost to a minimum. Any attempt to compress the liquid meets with resistance as the electron cloud of one molecule repels the electron cloud of the adjacent molecule. Liquids diffuse slowly, but in gases it is more rapid. It occurs because molecules have kinetic energy and move from one place to another .In a liquid ,molecules do not move very far before they collide with neighbouring molecules. i) What is the nature of the liquids? ii) What does kinetic theory say about the incompressible nature of liquids? iii) What are the different kinds of matter? iv) Give the meaning for ‘diffusion’? v) Why diffusion is more rapid in gases? vi) Give the antonym for ‘kinetic’. vii) Mention a suitable title.			7	2,5	K3

<b>UNIT-II</b>					
<b>3</b>	<b>a.</b>	Compose an essay on the relevance of Nehru's letter to Indira to the present context.	7	2	K3
	<b>b.</b>	Write antonyms and construct sentences for any SEVEN of the following words . i) procreate ii) hectic iii) reckon iv) beguile v) opulent vi) suffuse vii) astute viii) mandatory	7	5	K3
<b>OR</b>					
<b>4</b>	<b>a.</b>	Formulate a precis for the following passage. Most of us use the products of science – railways, aeroplanes, electricity, wireless and thousands of others – without thinking how they came into existence. We take them for granted, as if we were entitled to them as a matter of right. We are very proud of the fact that we live in an advanced age and are ourselves very advanced. Now, there is no doubt that our age is very different from previous ages and I think it is perfectly correct to say that is far more advanced. But it is a different thing from saying that we, as individuals or groups, are more advanced. It would be the height of absurdity to say that because an engine driver can run an engine and Plato or Socrates could not, the engine driver is more advanced than, or is superior to, Plato or Socrates. But it would be perfectly correct to say that the engine itself is a more advanced method of locomotion than Plato's chariot was.	7	2	K3
	<b>b.</b>	Write meanings and bring out the difference in usage for any FOUR of the following homonyms. i) Affect/Effect ii) Continuous/ Continual iii) Veracious/Voracious iv) Facilitate/Felicitate v) Apposite/Opposite vi) Intelligent/ Intelligible	7	5	K3
<b>UNIT-III</b>					
<b>5</b>	<b>a.</b>	Compose an essay on "Stephen Hawking – Positivity 'Benchmark'".	7	2	K3
	<b>b.</b>	Draft a letter to the educational consultancy asking about the information regarding the post-graduation and research programmes in foreign universities.	7	4	K3
<b>OR</b>					
<b>6</b>	<b>a.</b>	Write an E-mail to the manufacturer complaining about the computer that you bought recently.	7	4	K3
	<b>b.</b>	Draft a resume and covering letter for the post of a software engineer.	7	4	K3
<b>UNIT-IV</b>					
<b>7</b>	<b>a.</b>	Summarize the essay "Liking a Tree, Unbowed"?	7	2	K3
	<b>b.</b>	Give the meaning and write sentences of any SEVEN of the following FOREIGN PHRASES. i) ab initio ii) a la mode iii) siesta iv) amour proper v) ad hoc vi) Alma Mater vii) alter ego viii) bonafide	7	5	K3
<b>OR</b>					
<b>8</b>	<b>a.</b>	Write a pamphlet on book exhibition/ tour.	7	2	K3
	<b>b.</b>	Construct Sentences through the transformation of the following sentences as indicated.	7	5	K3

		<p>i. They painted the house green. (Add a question tag)</p> <p>ii. Do it. (Change the voice)</p> <p>iii) He said to the boy, “What are you doing here.” (Convert it into Indirect Speech)</p> <p>iv) My father said that Honesty is the best policy. (Convert it into direct Speech)</p> <p>v) They were very poor. They had insufficient food for themselves. They invited the strangers to dinner. (Change it into Complex)</p> <p>vi) The old man being weak could not walk properly. (Change it into Compound)</p> <p>vii). Shakespeare is the most famous of all writers in English. (Change it into positive degree)</p>			
<b>UNIT-V</b>					
<b>9</b>	<b>a.</b>	Elaborate the message which the author communicates to the readers through the lesson “Stay Hungry-Stay Foolish”.	7	2	K3
	<b>b.</b>	<p>Correct and Re-construct any SEVEN of the following Sentences.</p> <p>i) One must use his best efforts if he wishes to succeed.</p> <p>ii) Since he came, we are happy.</p> <p>iii) I could hardly believe in my eyes.</p> <p>iv) Suppose, if you arrive late, you will miss the show.</p> <p>v) Neither Jack is intelligent nor hardworking.</p> <p>vi) Hardly the sun had risen when we set out.</p> <p>vii) It is high time she improves her behaviour.</p> <p>viii) She gave me many informations.</p>	7	5	K3
<b>OR</b>					
<b>10</b>	<b>a.</b>	Compile a report to the editor about the problem of brain drain in India	7	4	K3
	<b>b.</b>	<p>Fill in the blanks with the appropriate choices.</p> <p>i) The film Titanic was promoted with all the usual _____</p> <p>a) hyperbole    b) dialect    c) taboo    d) aesthetic</p> <p>ii) The schedule of a few planes was _____ due to heavy smog.</p> <p>a) prohibited    b) abated    c) impeded    d) bolstered</p> <p>iii) Einstein had never bothered by the flood of _____ from his fellow critics.</p> <p>a) recantation    b) castigation    c) vituperation    d) skepticism</p> <p>iv) The field had been _____ by heavy downpour last night.</p> <p>a) tirade    b) fluctuated    c) mixed    d) saturated</p> <p>v) Modi is good at giving _____ speeches.</p> <p>a) extempore    b) prepared    c) epilogue    d) long</p> <p>vi) The manuscript was reproduced in _____ .</p> <p>a) facsimile    b) archives    c) cache    d) vacillation</p> <p>vii) Examine the report carefully before you _____ it publicly in front of the press and media.</p> <p>a) rescind    b) repudiate    c) revere    d) redress</p>	7	5	K3

\*\*\*\*\*

Course Code: B20BS1101				
SAGI RAMA KRISHNAM RAJU ENGINEERING COLLEGE (A)			R20	
I B.Tech I Semester –MODEL PAPER				
MATHEMATICS – I				
(LINEAR ALGEBRA AND DIFFERENTIAL EQUATIONS)				
Common to AIDS, CE, CSE, ECE, EEE, IT & ME				
TIME: 3 Hrs.		Max. Marks: 70 M		
Answer any One Question from Each Unit				
All questions carry equal marks				
UNIT-I		M	CO	KL
1.a)	Solve the system of equations $20x + y - 2z = 17$ , $3x + 20y - z = -18$ , $2x - 3y + 20z = 25$ by Gauss –Siedel method.	7	CO1	K3
b)	Investigate the values of $\lambda$ and $\mu$ so that the equations $2x + 3y + 5z = 9$ ; $7x + 3y - 2z = 8$ ; $2x + 3y + \lambda z = \mu$ ; have (i) no solution (ii) unique solution (iii) infinite number of solutions.	7	CO1	K3
(OR)				
2. a)	Solve the system of equations $10x + y+z =12$ , $2x+10y+z =13$ , $2x+2y+10z =14$ by Gauss- elimination method.	7	CO1	K3
b)	Define rank and determine the rank of the matrix A by reducing it to its normal form where A is: $A = \begin{bmatrix} 2 & 3 & -1 & -1 \\ 1 & -1 & -2 & -4 \\ 3 & 1 & 3 & -2 \\ 6 & 3 & 0 & -7 \end{bmatrix}$	7	CO1	K3
UNIT-II				
3.a)	Verify Cayley-Hamilton theorem and use the theorem to determine the inverse of the matrix $A = \begin{bmatrix} 1 & 0 & 3 \\ 2 & 1 & -1 \\ 1 & -1 & 1 \end{bmatrix}$	7	CO2	K3
b)	Reduce the quadratic form $2x^2 + 2y^2 + 2z^2 - 2xy - 2yz - 2zx$ to canonical form by the use of an orthogonal transformation.	7	CO2	K3
(OR)				
4. a)	Determine the Eigen values and the corresponding Eigen vectors of the matrix $A = \begin{bmatrix} 8 & -6 & 2 \\ -6 & 7 & -4 \\ 2 & -4 & 3 \end{bmatrix}$	7	CO2	K3
b)	If $A = \begin{bmatrix} 3 & 1 \\ -1 & 2 \end{bmatrix}$ , use Cayley-Hamilton theorem to determine the value of $2A^5 - 3A^4 + A^2 - 4I$ . Also determine the inverse of A.	7	CO2	K3

<b>UNIT-III</b>				
5.a)	Solve $\frac{dy}{dx} + (\tan x)y = (\sec x)y^3$ .	7	CO3	K3
b)	Solve $(y^4 + 2y)dx + (xy^3 + 2y^4 - 4x)dy = 0$ .	7	CO3	K3
<b>OR</b>				
6. a)	Determine the orthogonal trajectories of the family of parabolas $ay^2 = x^3$ .	7	CO4	K3
b)	A body originally at $80^\circ\text{C}$ , cools down to $60^\circ\text{C}$ in 20 minutes, the temperature of air being $40^\circ\text{C}$ . Determine the temperature of the body after 40 minutes from the original?	7	CO4	K3
<b>UNIT-IV</b>				
7.a)	Solve $(D^3 - D)y = 2x + 1 + 4 \cos x$ .	7	CO5	K3
b)	Solve $\frac{d^2y}{dx^2} - 2\frac{dy}{dx} + y = e^x \log x$ by the method of variation of parameters.	7	CO5	K3
<b>OR</b>				
8. a)	Solve $(D^2 + 3D + 2)y = e^{e^x}$ .	7	CO5	K3
b)	Use method of variation of parameters to solve the equation $\frac{d^2y}{dx^2} + y = \operatorname{cosec} x$ .	7	CO5	K3
<b>UNIT-V</b>				
9.a)	Determine $L\{t \cos at\}$ and $L\left\{\int_0^t e^{-t} \cos t dt\right\}$ .	7	CO6	K3
b)	Using convolution theorem evaluate $L^{-1}\left\{\frac{1}{(s+a)(s+b)}\right\}$ .	7	CO6	K3
<b>OR</b>				
10. a)	Determine $L^{-1}\left\{\frac{5s+3}{(s-1)(s^2+2s+5)}\right\}$ .	7	CO6	K3
b)	Solve $\frac{d^2y}{dt^2} + 4\frac{dy}{dt} + 3y = e^{-t}$ , $y(0) = y'(0) = 1$ by using Laplace transforms.	7	CO6	K3

\*\*\*\*\*

**APPLIED CHEMISTRY**

Common to CSE,ECE &amp; IT

**Time: 3 Hrs.****Max. Marks:70**

Answer any one Question from Each Unit

All questions carry equal Marks

			M	CO	KL
<b>UNIT-I</b>					
1	a.	Explain the mechanism of free radical Polymerization reaction with a suitable example.	7	CO1	K2
	b.	Distinguish between thermoplastic and thermosetting resins	7	CO1	K3
<b>OR</b>					
2	a.	What are conducting Polymers? Discuss the applications of conducting Polymers.	7	CO1	K2
	b.	Write notes on Bu Na – S and Bu Na – N.	7	CO1	K2
<b>UNIT-II</b>					
3	a.	Explain the Proximate analysis of coal and give its significance.	7	CO3	K2
	b.	Explain Photovoltaic cell with neat diagram.	7	CO3	K2
<b>OR</b>					
4	a.	Explain the fractional distillation of crude oil	7	CO3	K2
	b.	How synthetic Petrol can be prepared by Berguis Process.	7	CO3	K2
<b>UNIT-III</b>					
5	a.	Explain the mechanism of electrochemical theory of corrosion with neat diagram	7	CO2	K2
	b.	Describe briefly about cathodic Protection.	7	CO2	K3
<b>OR</b>					
6	a.	Explain Hydrogen – Oxygen fuel cell with neat cell diagram	7	CO4	K2
	b.	Discuss about Lithium batteries	7	CO4	K2
<b>UNIT-IV</b>					
7	a.	What is hardness? How it is determined by EDTA method? Explain	7	CO2	K2
	b.	Describe with equations how water can be softened using Lime & Soda Process	7	CO2	K2
<b>OR</b>					
8	a.	Discuss various sterilizing methods used in municipal water treatment	7	CO2	K2
	b.	Illustrate the reverse osmosis Process with a neat diagram	7	CO2	K2
<b>UNIT-V</b>					
9	a.	Discuss chemistry involved in setting and hardening of cement?	7	CO4	K2
	b.	What are refractories? Discuss the classification of refractories.	7	CO4	K2
<b>OR</b>					
10	a.	Write the engineering applications of Liquid Crystals.	7	CO3	K2
	b.	Explain the stoichiometric defects in crystals.	7	CO3	K2

\*\*\*\*\*

Course Code: B20 CS 1101						
SAGI RAMA KRISHNAM RAJU ENGINEERING COLLEGE (A)					R 20	
I B. Tech I Semester MODEL QUESTION PAPER						
PROGRAMMING FOR PROBLEM SOLVING USING C						
(Common to AIDS, CSE , ECE & IT )						
Time: 3 Hrs.			Max. Marks:70			
Answer any one Question from Each Unit						
All questions carry equal Marks						
				M	CO	KL
UNIT-I						
1	a.	What do you mean C Variable, C Constants? Explain in detail	7M	CO1	K1	
	b.	Explain Expressions Precedence and Associativity in detail	7M	CO1	K2	
OR						
2	a.	Explain types of storage classes in C	7M	CO1	K2	
	b.	Write the basic structure of C program and explain each and every step	7M	CO1	K2	
UNIT-II						
3	a.	Explain logical, bitwise operators with examples	7M	CO2	K2	
	b.	Differentiate two-way selection and multi-way selection	7M	CO2	K2	
OR						
4	a.	What is the difference between Pre-test loop and Post-test Loop with an example	7M	CO2	K2	
	b.	Discuss Event and Counter controlled loops	7M	CO2	K2	
UNIT-III						
5	a.	What is an Array? Define and initialize 1-D, 2-D Arrays	7M	CO3	K1	
	b.	Write a program to evaluate the average of values in an Array	7M	CO3	K3	
OR						
6	a.	Explain declaration and initialization of Array of Strings	7M	CO3	K2	
	b.	What is an Union? List the difference between Structures and Unions	7M	CO3	K1	
UNIT-IV						
7	a.	Explain the concept of Array of Pointers with example	7M	CO4	K2	
	b.	With proper example explain different arithmetic operators on Pointers	7M	CO4	K2	
OR						
8	a.	Explain L and R values in C Language and how are they used in C Language	7M	CO4	K2	
	b.	Discuss various Processor Commands	7M	CO4	K2	
UNIT-V						
9	a.	How to pass Array to a Function in C	7M	CO5	K2	
	b.	Discuss the Types of Functions in C	7M	CO5	K2	
OR						
10	a.	What is Stream? Describe two different methods of creating a Stream-Oriented data file	7M	CO5	K1	
	b.	Write a program to Copy contents from one File to another File	7M	CO5	K1	

\*\*\*\*\*

<b>Course Code: B20 EC 1101</b>					
<b>SAGI RAMA KRISHNAM RAJU ENGINEERING COLLEGE (A)</b>					<b>R 20</b>
I B. Tech I Semester MODEL QUESTION PAPER					
<b>BASIC ELECTRONICS</b>					
Electronics & Communication Engineering					
<b>Time: 3 Hrs.</b>			<b>Max. Marks:70</b>		
Answer any one Question from Each Unit					
All questions carry equal Marks					
			<b>M</b>	<b>CO</b>	<b>KL</b>
<b>UNIT-I</b>					
1.	a).	Write a brief note on charging and discharging action of a capacitor.	7	2	K1
	b).	Explain inductance and mutual inductance of an inductor?	7	2	K2
<b>OR</b>					
2.	a).	With a neat sketch explain basic operation of CRO?	7	2	K2
	b).	What are KVL and KCL? Explain each with an example?	7	2	K2
<b>UNIT-II</b>					
3.	a).	Describe intrinsic and extrinsic semiconductors?	7	1	K2
	b).	Derive expressions for mobility in semiconductors?	7	1	K1
<b>OR</b>					
4.	a).	What is Hall-effect? What are its applications?	7	1	K1
	b).	Explain Phenomenon of Drift and Diffusion in semiconductors?	7	1	K2
<b>UNIT-III</b>					
5.	a).	Explain basic operation and V-I characteristics of semiconductor diode?	7	3	K2
	b).	What is Zener diode? Explain its operation in reverse bias condition along with its applications?	7	3	K2
<b>OR</b>					
6.	a).	Draw and explain the operation of a full wave rectifier?	7	3	K2
	b).	Explain construction and operation of photo-diode?	7	3	K2
<b>UNIT-IV</b>					
7.	a).	Plot the input and output characteristics of transistor in CE configuration?	7	4	K1
	b).	List and Explain the fabrication steps of Monolithic ICs?	7	4	K2
<b>OR</b>					
8.	a).	Explain CC configuration of transistor?	7	4	K2
	b).	Write a brief note on transistor working as a switch.	7	4	K1
<b>UNIT-V</b>					
9.	a).	Convert the Decimal number 867.9 into Binary, Octal, and Hexadecimal?	7	5	K3
	b).	Explain operation and truth table of a) NAND b)NOR c)XOR gates.	7	5	K2
<b>OR</b>					
10.	a).	Explain operation and State Transition table of S-R flip-flop?	7	5	K2
	b).	Convert following Decimal numbers to Binary a)1101 b)1110.1111 c) 217.67	7	5	K3

\*\*\*\*\*



Answer any One Question from Each Unit

All questions carry equal marks

UNIT-I		M	CO	KL
1.a)	Determine the Fourier series for the function $f(t) = \begin{cases} -1, & -\pi < t < -\pi/2 \\ 0, & -\pi/2 < t < \pi/2 \\ 1, & \pi/2 < t < \pi \end{cases}$	7	CO1	K3
b)	Determine Fourier series of the function $f(x) = 2x - x^2$ in $(0, 3)$ and hence deduce that $\frac{1}{1^2} - \frac{1}{2^2} + \frac{1}{3^2} - \frac{1}{4^2} + \dots = \frac{\pi}{12}$ .	7	CO1	K3
<b>OR</b>				
2. a)	Determine Fourier series for the function $f(x)$ given by $f(x) = \begin{cases} 1 + \frac{2x}{\pi}, & \text{if } -\pi \leq x \leq 0 \\ 1 - \frac{2x}{\pi}, & \text{if } 0 \leq x \leq \pi \end{cases}$ and deduce that $\frac{1}{1^2} + \frac{1}{3^2} + \frac{1}{5^2} + \dots = \frac{\pi^2}{8}$ .	7	CO1	K3
b)	Determine the Half – Range cosine series for the function $f(x) = x^2$ in the range $0 \leq x \leq \pi$ .	7	CO1	K3
<b>UNIT-II</b>				
3.a)	Using the Fourier Sine Transform of $e^{-ax}$ ( $a > 0$ ), evaluate $\int_0^{\infty} \frac{x \sin kx}{a^2 + x^2} dx$ .	7	CO2	K3
b)	Using Fourier integral representation, establish that $\int_0^{\infty} \frac{\omega \sin \omega x}{1 + \omega^2} d\omega = \frac{\pi}{2} e^{-x}, x > 0$ .	7	CO2	K3
<b>OR</b>				
4. a)	Determine the inverse Fourier sine transform $f(x)$ of $F_s(p) = \frac{p}{1+p^2}$ .	7	CO2	K3
b)	Using Parseval's Identity, establish that $\int_0^{\infty} \frac{x^2}{(1+x^2)^2} dx = \frac{\pi}{4}$ .	7	CO2	K3
<b>UNIT-III</b>				
5.a)	If $U = \tan^{-1} \frac{x^3+y^3}{x-y}$ and $x U_x + y U_y = \sin 2U$ , establish that $x^2 U_{xx} + 2xy U_{xy} + y^2 U_{yy} = 2 \cos 3U \sin U$ .	7	CO3	K3
b)	If $u = x^2 - 2y^2, v = 2x^2 - y^2$ where $x = r \cos \theta, y = r \sin \theta$ then establish that $\frac{\partial(u,v)}{\partial(r,\theta)} = 6 r^3 \sin 2\theta$ .	7	CO3	K3
<b>OR</b>				

6. a)	Develop $x^2y + 3y - 2$ in a Taylor series in powers of $(x - 1)$ and $(y + 2)$ using Taylor's theorem.	7	CO4	K3
b)	By using the method of differentiation under the integral sign establish that $\int_0^\infty \frac{\tan^{-1}(ax)}{x(1+x^2)} dx = \frac{\pi}{2} \log(1+a)$ , $a \geq 0$ .	7	CO4	K3
<b>UNIT-IV</b>				
7. a)	Solve $x^2(y-z)p + y^2(z-x)q = z^2(x-y)$ .	7	CO5	K3
b)	solve $(D^2 - DD' - 2D'^2)z = (y-1)e^x$ .	7	CO5	K3
<b>OR</b>				
8. a)	Solve $x(y-z)p + y(z-x)q = z(x-y)$ .	7	CO5	K3
b)	solve $(D + D' - 1)(D + 2D' - 3)z = 3x + 6y + 4$ .	7	CO5	K3
<b>UNIT-V</b>				
9.a)	Determine the solution of $\frac{\partial u}{\partial x} + \frac{\partial u}{\partial y} = 0$ by the method of separation of variables.	7	CO6	K3
b)	A tightly stretched elastic string of length L, fixed at its end points is initially in a position given by $u(x, 0) = u_0 \sin^3 \frac{\pi x}{L}$ . If it is released from rest, determine the displacement at any subsequent time.	7	CO6	K3
<b>OR</b>				
10.a)	Determine the solution of $x \frac{\partial u}{\partial x} + y \frac{\partial u}{\partial y} = 0$ by the method of separation of variables.	7	CO6	K3
b)	A bar of conducting material of length $\pi$ units is initially kept at a temperature $\sin x$ . Determine the temperature at any subsequent time if the ends of the bar are held at zero temperature.	7	CO6	K3

\*\*\*\*\*

Course Code: B20BS1202

SAGI RAMA KRISHNAM RAJU ENGINEERING COLLEGE (A)

R 20

I B. Tech II Semester - MODEL QUESTION PAPER

APPLIED PHYSICS

(Common to CSE, ECE & IT)

Time: 3 Hrs.

Max. Marks: 70

Answer any one Question from Each Unit

All questions carry equal Marks

M CO KL

UNIT-I

1	a.	Explain the principle of Superposition and discuss the conditions for maxima and minima of intensity.	6	1	2
	b.	How the Newton's Rings are formed and deduce an expression for the wave length of light used.	8	1	3

OR

2	a.	Distinguish the different types of diffractions of light.	6	1	2
	b.	Give qualitative and quantitative analysis of Fraunhofer diffraction at a single slit	8	1	3

UNIT-II

3	a.	Define polarization and explain the different types of polarization possible in a dielectric	6	2	2
	b.	Deduce the Clausius Mosottirelation and its significance in dielectrics.	8	2	3

OR

4	a.	Define Magnetic susceptibility and give a classification of magnetic materials.	6	2	1
	b.	Describe the Hysteresis exhibited by Ferromagnetic materials and explain its using a suitable theory	8	2	3

UNIT-III

5	a.	Give the selection procedure of the active medium of laser device.	6	3	2
	b.	With suitable diagrams, discuss the working principle, design and working of He - Ne laser system	8	3	3

OR

6	a.	What is the significance of Numerical Aperture of an optical fiber and obtain an expression for it.	8	3	2
	b.	Discuss the sensor applications of optical fibers.	6	3	3

UNIT-IV

7	a.	What is an intrinsic semiconductor and obtain an expression for the density of carriers.	8	4	3
	b.	Distinguish between direct and indirect band gap semiconductors and mention their applications.	6	4	2

OR

8	a.	Discuss the Hall Effect in detail and explain its significance.	8	4	3
	b.	Distinguish between drift and diffusion current in semiconductors.	6	4	2

<b>UNIT-V</b>					
9	a.	Explaining Magnetostriction effect, describe how the ultrasonics can be produced.	8	5	3
	b.	Mention the applications of ultrasonics.	6	5	1
<b>OR</b>					
10	a.	How the nano materials can be produced by sol – gel method.	6.	5	3
	b.	Write about Carbon Nanotubes	4	5	2
	C.	Discuss some important applications of nanomaterials.	4	5	1

\*\*\*\*\*

Time: 3 Hrs.

Max. Marks: 70

Answer any one Question from Each Unit

All questions carry equal Marks

M CO KL

## UNIT-I

1	a.	Derive the EMF equation of DC generator	7M	1	3
	b.	A shunt generator supplies a load of 7.5KW at 200V, Calculate the generated emf if armature resistance is $0.6\Omega$ and field resistance of $80\Omega$ .	7M	1	3

OR

2	a.	Explain the speed control methods of DC shunt motor with neat sketches	7M	1	3
	b.	An 8-pole, wave-connected armature has 600 conductors and is driven at 625 rev/min. If the flux per pole is 20 milli weber, determine the generated E.M.F.	7M	1	3

## UNIT-II

3	a.	Discuss the Analysis of single-phase ac circuits consisting of pure inductor.	7M	2	3
	b.	Find the average value, R.M.S value, form factor and peak factor for the wave form shown in figure.	7M	2	3

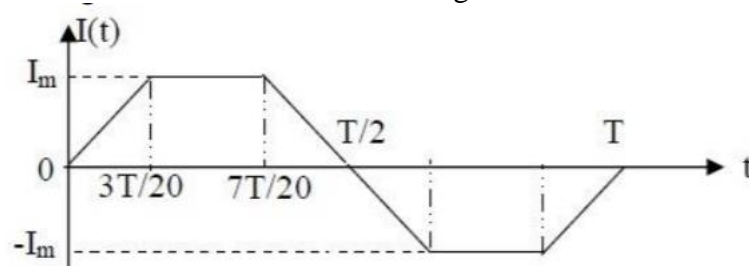

OR

4	a.	Derive Average and RMS value of a sinusoidal waveform	7M	2	3
	b.	A 200 V, 50 Hz AC supply is applied to a coil of 0.08 H inductance and $3.5\Omega$ Resistance connected in series with a $7.2\mu\text{F}$ capacitor. Calculate (i) Impedance (ii) Current (iii) Phase angle between current and voltage (iv) power factor (v) power consumed.	7M	2	3

## UNIT-III

5	a.	Explain the Principle of operation of single-phase transformer.	7M	3	3
	b.	An ideal 25KVA Transformer has 500 turns on primary and 40 turns on the secondary winding. The primary winding is connected to 3000 V, 50Hz supply. Calculate (i) Primary and secondary currents (ii) Secondary EMF (iii) Maximum flux.	7M	3	3

OR

6	a.	Explain about OC and SC tests on a Single phase Transformer.	7M	3	3
---	----	--	----	---	---

	b.	A 200 KVA rated transformer has a full-load copper loss of 1.5 kW and an iron loss of 1 kW. Determine the transformer efficiency at full load & half load for 0.85 power factor	7M	3	3
<b>UNIT-IV</b>					
7	a.	Explain the construction and working principle of three phase induction motor.	7M	4	3
	b.	The stator of a 3-phase, 4-pole induction motor is connected to a 50 Hz supply. The rotor runs at 1455 rev/min at full load. Determine (i) the synchronous speed and (ii) the slip at full load.	7M	4	3
<b>OR</b>					
8	a.	Draw and explain Slip-Torque characteristics of Three phase Induction Motor.	7M	4	3
	b.	If the induced emf in the stator of an 8 pole induction motor has a frequency of 50 Hz and that in the rotor is 1.5 Hz, at what speed is the motor running and what is the slip?	7M	4	3
<b>UNIT-V</b>					
9	a.	Explain the construction and working principle of Synchronous Generator.	7M	5	3
	b.	Explain about the regulation of alternator by synchronous impedance method.	7M	5	3
<b>OR</b>					
10	a.	Explain the Construction and working principle of Synchronous motor.	7M	5	3
	b.	Explain the starting methods of synchronous motors.	7M	5	3

\*\*\*\*\*

**ENGINEERING DRAWING**

(For ECE)

**Time: 3 Hrs.****Max. Marks:70**

Answer any one Question from Each Unit

All questions carry equal Marks

**UNIT-I****M****CO****KL**

1	An inelastic string 145 mm long has its one end attached to the circumference of a circular disc of 40 mm diameter. Draw the curve traced out by the other end of the string, when it is completely wound around the disc, keeping the string always tight.	14	1	K3
---	---	----	---	----

**OR**

2	Construct a parabola when the distance of the focus from directrix is 50mm. Also draw the tangent and normal at any point on the curve.	14	1	K3
---	---	----	---	----

**UNIT-II**

3	a.	Draw the projections of the following points on the same ground line, keeping the projectors 25mm apart. (i) Point A in the HP and lying 20mm behind the VP; (ii) Point B is 40mm above the HP and 25mm in front of the VP; (iii) Point C is 25mm below the HP and 25mm behind the VP; (iv) Point D is 15mm above the HP and 50mm behind the VP.	7	2	K3
	b.	Draw the projections of a 75mm long straight line in the following positions: (i) parallel to and 30mm above the HP and in the VP; (ii) perpendicular to the VP, 25mm above the HP and its one end in the VP; (iii) Inclined at $30^{\circ}$ to the HP and its one end 20mm above it, parallel to and 30mm in front of the VP.	7	2	K3

**OR**

4	A line AB, of 80 mm long has its end A, 15 mm in front of VP and 20 mm above HP. The other end B is 40 mm above HP and 50 mm in front of VP. Draw the projections of the line and determine the inclinations of the line with HP and VP.	14	2	K3
---	--	----	---	----

**UNIT-III**

5	Draw a rhombus of diagonals 100 mm and 60 mm long, with the longer diagonal horizontal. The figure is the top view of a square of 100mm long diagonals, with a corner on the ground. Draw its front view and Determine the angle which its surface makes with the ground.	14	3	K3
---	---	----	---	----

**OR**

6	A semicircular plate of 40mm diameter has its straight edge in the VP and	14	3	K3
---	---	----	---	----

	inclined at $45^{\circ}$ to the HP, the surface of the plate makes an angle of $30^{\circ}$ with the VP. Draw its projections.			
<b>UNIT-IV</b>				
7	A hexagonal pyramid, base 25mm side and axis 50mm long, has an edge of its base on the ground. Its axis is inclined at $30^{\circ}$ to the ground and parallel to the VP. Draw its projections.	14	4	K3
<b>OR</b>				
8	A hexagonal pyramid, base 30 mm side and axis 75 mm long, resting on its base on HP with two of its edges parallel to VP is cut by two section planes both perpendicular VP. The horizontal section plane cuts the axis at a point 35 mm from the apex. The other plane which makes an angle of $45^{\circ}$ with the HP also intersects the axis at the same point. Draw the front view, sectional top view and true shape of section	14	4	K3
<b>UNIT-V</b>				
9	A cone of base diameter 50 mm and axis 60 mm is resting on its base on the HP. Draw the development of its lateral surface when it is cut by an auxiliary inclined plane inclined at $60^{\circ}$ to the HP and bisecting the axis.	14	5	K3
<b>OR</b>				
10	A square pyramid has its base side 40mm and height 60mm. Draw the isometric projection of the pyramid when the axis of the solid is horizontal and vertical.	14	5	K3

\*\*\*\*\*



Time: 3 Hrs.

Max. Marks: 70

Answer any one Question from Each Unit

All questions carry equal Marks

M CO KL

UNIT-I

1 a. Explain KCL and Infer  $V_x$  and  $i_o$  for the circuit shown in Fig. 1.

7M 1 2

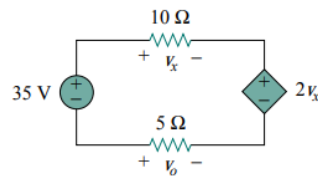

Fig. 1

b. Solve the circuit using Nodal analysis and find node voltages in the circuit shown in Fig. 2.

7M 1 3

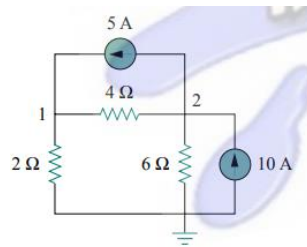

Fig. 2

OR

2 a. Model an equivalent resistance  $R_{ab}$  for the Fig. 3.

7M 1 3

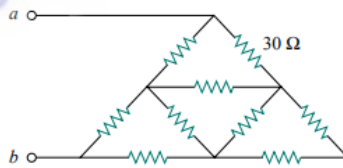

Fig. 3

b. Develop the Norton's circuit from the circuit given in Fig 4.

7M 1 3

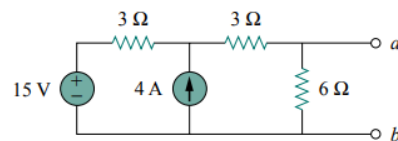
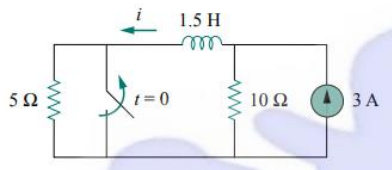

Fig. 4

**UNIT-II**

3	a.	<p><b>Solve</b> the circuit to get <math>i(t)</math> for <math>t &gt; 0</math> shown in Fig. 5</p>  <p align="center">Fig. 5</p>	7M	2	3
---	----	---	----	---	---

	b.	<p><b>What</b> is time constant? <b>Explain</b> its significance through one suitable example.</p>	7M	2	2
--	----	--	----	---	---

**OR**

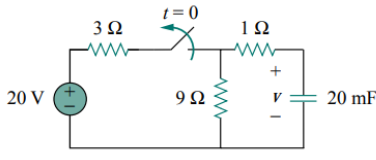
4	a.	<p><b>Solve</b> the circuit to get <math>V(t)</math> for <math>t &gt; 0</math> shown in Fig. 6.</p>  <p align="center">Fig. 6</p>	7M	2	3
---	----	--	----	---	---

	b.	<p><b>Explain</b> the response for voltage in a series RC circuit with derivation when subjected to a step input.</p>	7M	2	2
--	----	---	----	---	---

**UNIT-III**

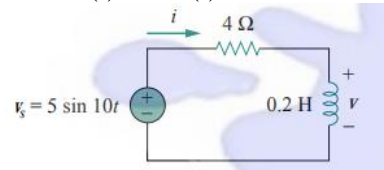
5	a.	<p><b>Solve</b> the circuit to calculate <math>V(t)</math> and <math>i(t)</math> for the circuit shown in Fig. 7.</p>  <p align="center">Fig. 7</p>	7M	3	3
---	----	---	----	---	---

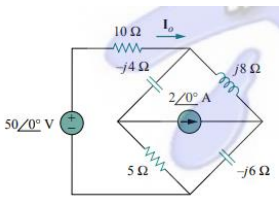
	b.	<p><b>Solve</b> the circuit to calculate current <math>I_o</math> shown in Fig. 8. using mesh analysis</p>  <p align="center">Fig. 8</p>	7M	3	3
--	----	---	----	---	---

**OR**

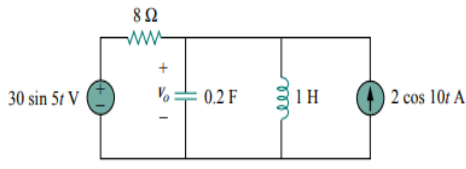
6	a.	<p><b>Solve</b> the circuit to get <math>V_o(t)</math> in the Fig .9. using superposition theorem.</p>  <p align="center">Fig. 9</p>	7M	3	3
---	----	---	----	---	---

	b.	<p><b>Deduce</b> the expression to find bandwidth in a parallel RLC circuit.</p>	7M	3	3
--	----	--	----	---	---

**UNIT-IV**

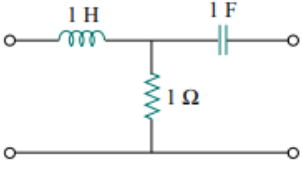
7	a.	<p><b>Model</b> Z parameters of the network shown in Fig .10.</p> <div style="text-align: center;">  </div> <p style="text-align: center;">Fig .10.</p>	7M	4	3
---	----	--	----	---	---

	b.	<p><b>Relate</b> ‘ABCD’ parameters in terms of ‘Y’ parameters.</p>	7M	4	3
<b>OR</b>					

8	a.	<p><b>Deduce</b> the condition for reciprocity and symmetry in ABCD parameters</p>	7M	4	3
	b.	<p><b>Explain</b> about parallel connection of two port network.</p>	7M	4	3

**UNIT-V**

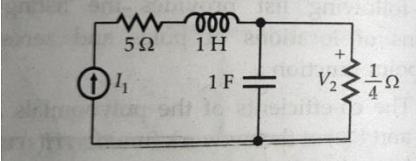
9	a.	<p><b>Develop</b> transfer impedance (<math>V_2/I_1</math>) for the network shown in Fig.11. and draw the pole zero plot for transfer impedance (<math>V_2/I_1</math>).</p> <div style="text-align: center;">  </div> <p style="text-align: center;">Fig. 11</p>	7M	5	3
---	----	--	----	---	---

	b.	<p><b>Explain</b> about restriction of poles and zeros in driving point function.</p>	7M	5	3
<b>OR</b>					

10	a.	<p><b>Examine</b> the stability of the following polynomial by applying Routh-Hurwitz criterion. <math>P(s)=S^4+2S^3+4S^2+12S+10</math>.</p>	7M	5	3
	b.	<p>A current transfer function is given by <math>I(s) = 5S/(s+2)(s^2+2s+2)</math> . <b>Model</b> its time domain response.</p>	7M	5	3

\*\*\*\*\*